



<https://doi.org/10.15407/scine17.04.011>

FIALKO, N. M. (<https://orcid.org/0000-0003-0116-7673>),
STEPANOVA, A. I. (<https://orcid.org/0000-0002-9297-8473>),
NAVRODSKA, R. O. (<https://orcid.org/0000-0001-7476-2962>),
GNEDASH, G. O. (<https://orcid.org/0000-0003-0395-9615>),
and SHEVCHUK, S. I. (<https://orcid.org/0000-0001-8046-0039>)
Institute of Engineering Thermophysics, the NAS of Ukraine,
2a, Mariia Kapnist St., Kyiv, 03057, Ukraine,
+380 44 453 2859, +380 44 456 9171, admin@ittf.kiev.ua

COMPLEX METHODS FOR ANALYSIS OF EFFICIENCY AND OPTIMIZATION OF HEAT-RECOVERY SYSTEMS

Introduction. *The solution to the energy conservation problem in Ukraine is associated with the need to increase the efficiency of power plants. Today, it is possible to study this problem in terms of exhaust gas heat recovery systems of fuel-fired thermal plants for various purposes from the standpoint of modern integrated approaches.*

Problem Statement. *One of the reasons hindering the widespread use of heat-recovery systems for these plants is a low efficiency of these systems because of imperfect existing methods for their analysis and the equipment used.*

Purpose. *The purpose of this research is to create complex methods for analyzing the efficiency and optimization of simply-configured heat-recovery systems and their individual elements.*

Materials and Methods. *Complex approaches based on exergy analysis methods, statistical experiment design methods, and modern methods of thermal calculation of heat-exchange equipment of heat-recovery systems have been used.*

Results. *Methods for analyzing the efficiency and optimizing heat-recovery systems of gas-fired heat plants, which are based on two techniques for obtaining functional dependencies for optimization of simple heat-recovery systems or their individual elements have been developed. Examples of using the proposed methods for improving water- and air-heater in heat-recovery systems for exhaust-gases from a glass melting furnace have been presented.*

Conclusions. *Complex approaches to the analysis of the efficiency and the optimization of heat-recovery systems of simple structure and their individual elements have been developed/ They are based on the methods for exergy analysis, statistical experiment design method, and modern methods of thermal calculation of heat transfer equipment of heat-recovery systems. The results of solving optimization problems allow increasing the efficiency of heat-recovery systems of gas-fired power plants of various types and will be used while designing of these systems.*

Key words: gas-fired heat plants, heat-recovery of exhaust gases, water- and air-heater, and efficiency criteria.

Citation: Fialko, N. M., Stepanova, A. I., Navrodska, R. O., Gnedash, G. O., and Shevchuk, S. I. Complex Methods for Analysis of Efficiency and Optimization of Heat-Recovery Systems. *Sci. innov.* 2021. V. 17, no. 4. P. 11–18. <https://doi.org/10.15407/scine17.04.011>

The solution to the general problem of energy conservation in Ukraine is associated with the need to improve the efficiency and to optimize the operation of power plants. Today, it is possible to study this problem in terms of exhaust gas heat recovery systems of fuel-fired thermal plants for various purposes from the standpoint of modern integrated approaches. Since heat of various potentials is used in heat-recovery systems, the analysis of the operation of such systems involves, with the aim of improving them, given the qualitative characteristics of energy and substance flows, which can be implemented with the use of exergy analysis methods. The aforementioned determines the importance and relevance of research in this area.

In the world practice of studying the efficiency and optimization of energy systems, attention is focused on the exergy analysis [1–5]. So, in [1], it has been noted that exergy analysis allows us to identify all aspects that affect the global efficiency of the system in order to offer them the maximum number of possible improvements. Research work [2] presents the results of studies of an integrated coal gasification system developed for the production of hydrogen and electricity production through energy analysis and exergy. Research [3] presents the results of studies the purpose of which is to develop modelling and to raise the performance of fuel cells by means of the study of their energy and exergy efficiency and by experimental optimization. The methods of exergy analysis used in the works mainly involve the use of exergy efficiency, which does not reflect some important aspects of the processes under study. For example, this does not take into account the purpose of the process, the ambiguity in the interpretation of beneficial effects and costs, the inability to localize exergy losses and determine the reasons that caused them. Therefore, it is advisable to use integrated approaches in assessing the performance of power plants. Research works [4] and [5] deal with the application of an integrated approach based on exergy analysis methods to the study of exergy losses in air-heater of a heat-recovery system of a

boiler plant. It has been noted in the research works that the applied methods enable establishing the causes of exergy losses and their localization areas and determining the parameter values within which the losses are minimum. Further researches in this field through the application of the proposed approaches to various systems have contributed to increasing the productivity and efficiency of various types of power plants and their heat-recovery systems, in particular.

The purpose of this research is to create comprehensive methods for analyzing the efficiency and optimizing simply-configured heat-recovery systems and their individual elements based on exergy analysis methods in combination with other modern research methods for gas-fired heat plants.

To achieve this goal, it is necessary to solve the following tasks:

- ◆ to develop a comprehensive methodology for the analysis of efficiency and optimization for heat-recovery systems of simple structure and their individual elements based on the use of balance methods of exergy analysis and statistical methods of experiment planning;
- ◆ to develop a complex method for the analysis of efficiency and optimization for air-heater of heat-recovery systems with the use of a system of exergy, thermal and material balance equations in conjunction with hydrodynamic equations and heat transfer equations;
- ◆ to show examples of using the proposed methods for water- and air-heaters of heat-recovery systems.

Integrated approaches based on exergy analysis methods, statistical experimental design methods, and modern methods of thermal calculation of heat-recovery exchange equipment for studying exergy efficiency and optimization of heat-recovery systems have been used in the research. Exhaust-gas heat-recovery exchangers with the use of two coolants for heated water and air have been considered.

The research paper proposes complex approaches to the analysis of the efficiency and optimization

tion of heat-recovery systems of simple structure and their individual elements, which formed the basis of the relevant research methods.

Within the framework of the proposed methods, two methods are considered for producing gas-fired heat plants with heat-recovery systems based on water and air heaters of functional dependences of exergy efficiency criteria on the main parameters of the systems, which is necessary for solving the corresponding optimization problems.

The establishment of these dependencies for heat-recovery systems of simple structure and their individual elements can be carried out in two ways:

- ◆ using the balance methods of exergy analysis and statistical methods of experiment planning, search for the mathematical model of the object under study in the form of a polynomial (regression equation);
- ◆ using the system of exergy, thermal and material balance equations together with hydrodynamic equations and heat transfer equations, to search for a functional relationship for a certain type of heat-recovery exchangers.

The shown general system of balance equations (1) for heat-recovery systems takes into account three situations:

- ◆ exhaust-gas moisture content can be neglected;
- ◆ the moisture content of the exhaust-gases after passing through the heat-recovery system or its individual elements remains constant;
- ◆ the moisture content of the exhaust-gases changes due to the condensation of the water vapor present in them.

$$\begin{aligned} \sum_{i=1}^n E_{iout} - \sum_{i=1}^n E_{iin} + \sum_{i=1}^n E_{li}^{tot} &= 0, \\ \sum_{i=1}^n G_{iin} h_{iin} - \sum_{i=1}^n G_{iout} h_{iout} &= 0, \\ \sum_{i=1}^n G_{iin} - \sum_{i=1}^n G_{iout} &= 0, \\ G_p^g c_p^g T_{in}^g - G_p^g c_p^g T_{out}^g - k^g \Delta TF &= 0, \\ G_p^a c_p^a T_{in}^a - G_p^a c_p^a T_{out}^a - k^a \Delta TF &= 0, \\ E_{in}^g - E_{out}^g = G_p^g \left[c_p^g (T_{in}^g - T_{out}^g) - \right. \\ \left. - T_{en} \left(c_p^g \ln \frac{T_{in}^g}{T_{out}^g} - \frac{R}{\mu^g} \ln \frac{p_{in}^g - p_{pp} T_{in}^g}{p_{out}^g - p_{pp} T_{out}^g} \right) \right] &- \end{aligned}$$

$$\begin{aligned} - G^g W_{out} (h_{pout} - T_{en} s_{pout}) + G^g W_{out} (h_{pen} - T_{en} s_{pen}) + \\ + G^g W_{in} G^g (h_{pin} - T_{en} s_{pin}) - G^g W_{in} (h_{ien} - T_{en} s_{ien}); \\ E_{out}^w - E_{in}^w = G^w (h_{out}^w - T s_{out}^w) - G^w (h_{in}^w - T s_{in}^w). \end{aligned} \quad (1)$$

When implementing the first method for finding the functional dependences necessary for optimization, the heat-exergy and exergy-technological efficiency criteria are determined, which are the optimization target functions: $\varepsilon = E_j/Q$, $k_{ex}^T = E_j m/Q^2$. With the use of statistical methods of experiment planning, functional dependences (2) of exergy efficiency criteria (response function) on the parameters of simple heat-recovery systems or their individual elements in the form of a quadratic polynomial (regression equation) have been established:

$$\begin{aligned} f(x_1 \dots x_n) = a_0 + \sum_{k=1}^n a_k x_k + \\ + \sum_{\substack{i,k=1 \\ i \neq k}}^n a_{ik} x_i x_k + \sum_{k=1}^n a_{kk} x_k^2. \end{aligned} \quad (2)$$

Minimization of the obtained functional dependences allows determining the optimal parameters of these systems. The minimum of the indicated functional dependences corresponds to the maximum exergy efficiency of the system. For a detailed study of the response surface in the minimum region, the contour curves in the minimum region, which are obtained by one of the methods of the experimental design theory, namely, the method of canonical transformations have been analyzed. Based on the exact values of the optimal parameters, the method allows varying their values within the minimum range so that the indicated parameter values are within the interval selected in accordance with the actual requirements for the operational and design features of heat-recovery exchangers.

Show an example of using the first method to optimize the geometric parameters of the heat exchange surface of a water heat-recovery exchanger of the exhaust-gases of a glass melting furnace. Water heat-recovery exchanger consists of a package of panels. The panels are formed by smooth pipes connected by external membranes. The pac-

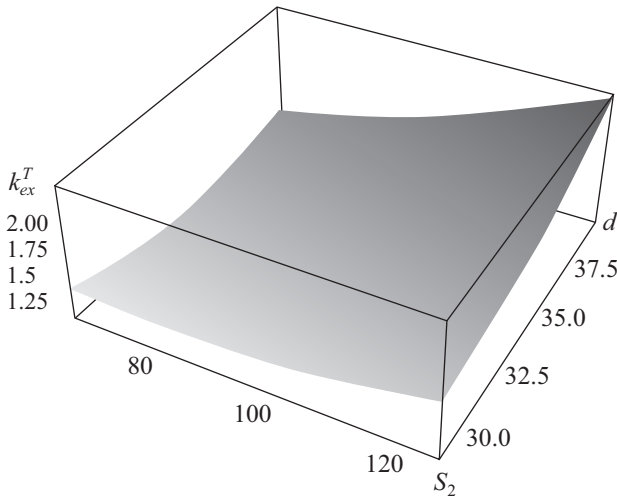

Fig. 1. Dependence of the exergo-technological efficiency criterion k_{ex}^T on the geometric parameters of the heat exchange surface of the water heat-recovery exchanger with checkerwise arrangement of pipes at $S_2 = 65$ mm

kage is a parallel-mounted panel, united by the pipe parts of the panels with the collectors with the corridor (or checkerwise) arrangement of pipes in this package. The heat exchanger uses a cross-flow scheme with one-way gas movement in the interpanel space and a multi-way flow of water in the pipes with the resulting circuit parameters close to countercurrent flow of heat-transfer agents [6].

To find the thermal and mass-dimensional characteristics of the heat exchanger, the following initial data are taken: heat exchange surface made of carbon steel; the initial temperature of the exhaust-gases is 400 °C, and the heat-transfer agent, which is heated (water) is 60 °C; exhaust-gases and water consumption, respectively, 3.7 and 14 kg/s; membrane thickness 0.002 m; pipe outer diameter 0.032 m, pipe wall thickness 0.003 m. The specified characteristics correspond to the range of practical operating values for the heat-recovery exchangers used [6].

Exergy efficiency criteria are used as optimization goal functions of optimization. The distance between the pipes in the panel s_2 , the outer diameter of the pipes d and the distance between the panels s_1 are selected as independent variable pa-

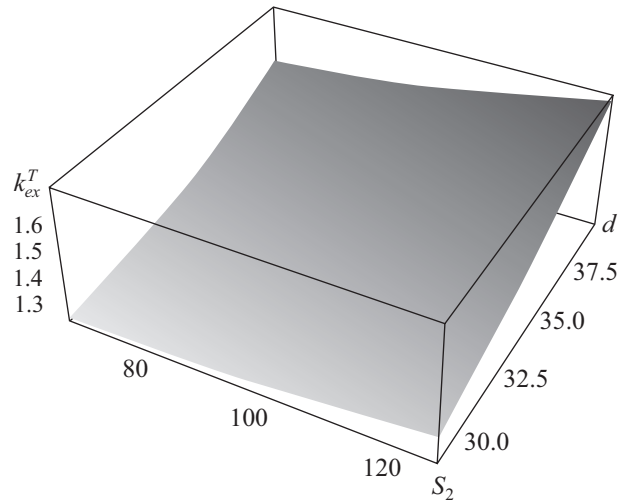

Fig. 2. Dependence of the exergo-technological efficiency criterion k_{ex}^T on the geometric parameters of the heat exchange surface of the water heat-recovery exchanger with corridor position of pipes at $S_2 = 65$ mm

rameters. For the indicated heat-recovery exchanger, as an example, the obtained regression dependences (3) and (4) are given, as well as the corresponding graphs (Fig. 1 and 2).

The checkerwise arrangement of pipes in a package of panels:

$$k_{ex}^T = 6.1 + 1.3 \cdot 10^{-4} s_1^2 + 2.0 \cdot 10^{-4} s_2^2 + 6.0 \cdot 10^{-3} d^2 - 2.0 \cdot 10^{-4} s_1 s_2 + 1.0 \cdot 10^{-3} s_1 d - 1.7 \cdot 10^{-3} s_2 d - 3.73 \cdot 10^{-2} s_1 + 6.91 \cdot 10^{-2} s_2 - 0.38 d. \quad (3)$$

The corridor position of pipes in a package of panels:

$$k_{ex}^T = 1.5 + 2.0 \cdot 10^{-5} s_1^2 - 2.0 \cdot 10^{-5} s_2^2 + 1.3 \cdot 10^{-3} d^2 - 1.2 \cdot 10^{-5} s_1 s_2 + 1.25 \cdot 10^{-4} s_1 d + 7.5 \cdot 10^{-5} s_2 d - 5.68 \cdot 10^{-3} s_1 + 1.72 \cdot 10^{-2} s_2 - 8.11 \cdot 10^{-2} d. \quad (4)$$

Minimization of the obtained functional dependencies made it possible to determine the optimal values of the geometric parameters of the heat exchange surface of the water heat-recovery exchanger. For the checkerwise position: $s_1 = 62$ mm, $s_2 = 68$ mm, $d = 42$ mm. For the corridor position: $s_1 = 58$ mm, $s_2 = 60$ mm, $d = 42$ mm. The value of the exergo-technological criterion of efficiency corresponding to the optimal values of

the geometric parameters for the checkerwise position of pipes in the panel package is less than the value of the exergo-technological criterion of efficiency for the corridor position of pipes by 10 %, which corresponds to the greater exergy efficiency of heat exchangers with the checkerwise arrangement of pipes.

The analysis of contour curves in the minimum area showed the possibility of varying the values of the outer diameter of the pipes somewhat larger compared to the possibility of varying the remaining geometric parameters in accordance with the actual requirements for the operational and design features of heat-recovery exchangers.

In the case of implementing the second method for determining the functional dependences necessary for optimization, a technique is proposed; and the dependences of exergy efficiency criteria on the input parameters of the heat-transfer agents and the geometric parameters of the heat transfer surface of the air-heaters for the heat-recovery systems of exhaust-gases of a glass melting furnace are established. The heat exchange surface of this heat-recovery exchanger also consists of a package of panels formed by pipes with membranes. Pipes from both ends are installed in the tube boards subject to the checkerwise or the corridor arrangement of the pipes in the package. Heat-transfer agents are move cross-flow, exhaust-gases moves in the interpanel space, and the air, those heats up, moves in the pipes. The basic input data for the thermal calculation and determination of the overall dimensions correspond to those indicated for the water heat-recovery exchanger. The difference lies in the temperature and flow rate of the heat-transfer agent, that is being heated, namely, the initial air temperature is taken equal to 0 °C, and its flow consumption is 2.5 kg/s.

The following expressions are obtained for the exergo-technological efficiency criterion:

$$k_{ex}^T = \left\{ \ln \left(1 + \frac{T_{in}^g - T_{in}^a}{CT_{in}^a \left((1 + \xi a_c^g) / a_r^g F_l + 1 a_c^a F_p^{ext} \right)} \right) + \right. \\ \left. + \ln \left(1 - \frac{(T_{in}^g - T_{in}^a) \Psi}{CT_{in}^g \left((1 + \xi a_c^g) / a_r^g F_l + 1 a_l^a F_p^{ins} \right)} \right) \right\} +$$

$$+ \frac{Rl\rho^a(\omega^a)^2}{2d_1c_p^a(1.82\ln Re^a - 1.64)^2 \mu^a p_{in}^a} + \\ + D \frac{R\rho^g(\omega^g)^2}{2\mu^g p_{in}^g c_p^g} \left\} \frac{T_{en} m C}{Q} \cdot \\ \omega^{g,a} = (Re^{g,a} \mu^{g,a}) / (\rho^{g,a} d_2);$$

$$Q = \Psi (T_{in}^g - T_{in}^a) / ((1 + \xi a_c^g) / a_r^g F_f + 1 / a_c^a F_{tp}^{ext}).$$

For the checkerwise arrangement:

$$D = 0.25 (z + 1); \\ a_r^g = 0.127 (s_1/d_2)^{-0.7} (Re^g)^{0.75} \cdot \\ \cdot \lambda^g [H + 1.1 F_p^{ext} (1 - H) / F_f] / d_2; \\ a_c^a = k_T 0.022 (Re^a)^{0.8} (Pr^a)^{0.43} \lambda^a / d_1; \\ H = th (ph_m) / ph_m; p = \sqrt{\frac{2a_c^g v_m}{\lambda_m b (1 + \xi a_c^g)}}; \\ v_m = \frac{F_f}{F_m} \left(1 - v_p \frac{F_p^{ext}}{F_f} \right);$$

$$F_p^{ins} = lN\pi d_1; F_p^{ext} = lN\pi d_2; F_m = lN (4s_2 - 2d_2); \\ F_f = lN (4s_2 - 2d_2 + \pi d_2); h_m = 0.5 (2s_2 - d_2).$$

For the corridor arrangement:

$$D = 0.074 \left(\frac{s_1/d_1 - 1}{s_2/d_2 - 1} \right)^{-1.5} z; \\ a_r^g = 0.051 (Re^g)^{0.75} \cdot \lambda^g [H + 1.1 F_p^{ext} (1 - H) / F_f] / d_2; \\ H = th (ph_m) / ph_m; p = \sqrt{\frac{2a_c^g v_m}{\lambda_m b (1 + \xi a_c^g)}}; \\ v_m = \frac{F_f}{F_m} \left(1 - 1.1 \frac{F_p^{ext}}{F_f} \right);$$

$$F_p^{ins} = lN\pi d_1; F_p^{ext} = lN\pi d_2; F_m = 2lN (s_2 - d_2); \\ F_f = 2lN (s_2 - d_2 + 0.5\pi d_2); h_m = 0.5 (s_2 - d_2).$$

As an example, for air-heater with the checkerwise and the corridor pipe arrangement at the panels, Fig. 3 shows the dependences of the exergo-technological efficiency criterion $k_{ex}^T = E_{\dot{m}} / Q_2$ from the ratio of Reynolds numbers Re^g / Re^a . The minimum on the graphs corresponds to the optimal values of the parameters.

As can be seen from the graphs presented, the exergo-technological efficiency criteria both in the case of checkerwise arrangement of pipes in a panel package and in the case of the corridor position increase, as Re^a decreases, practically over

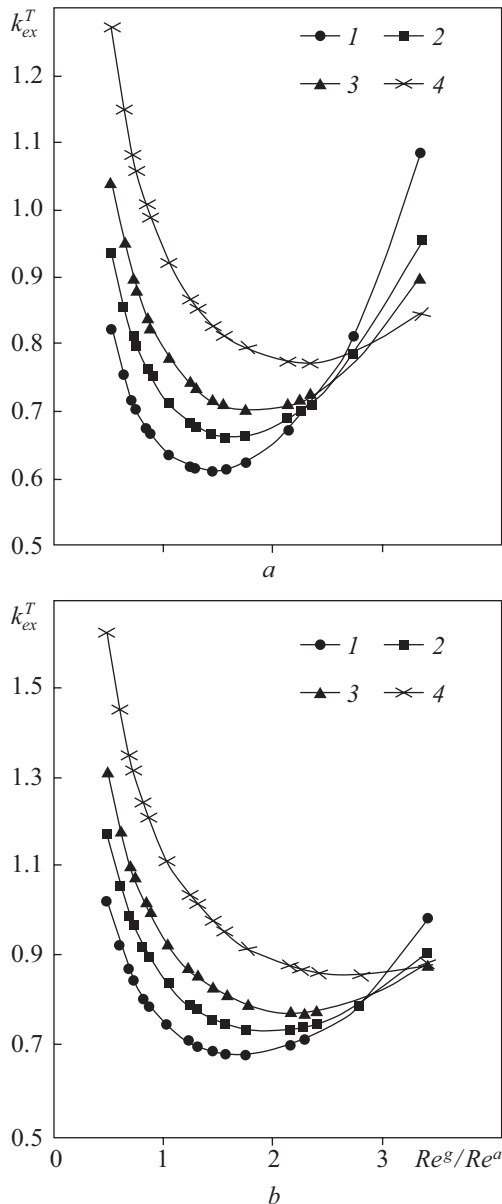

Fig. 3. The dependences of the exergo-technological efficiency criterion k_{ex}^T from the ratio of Reynolds numbers Re^g/Re^a : a – checkerwise arrangement of pipes, b – corridor position of pipes, $1 - Re^a = 15000$; $2 - 12000$; $3 - 10000$; $4 - 7000$

the entire range of the ratio of Reynolds numbers Re^g/Re^a , which corresponds to an increase in the exergy efficiency of heat exchangers.

The optimal ratio of Reynolds numbers Re^g/Re^a corresponding to the minimum of the obtained functional dependences increases, as Re^a decreases.

The exergo-technological criteria of efficiency, corresponding to the optimal values of operating parameters for the checkerwise arrangement of pipes in a panel package, are by 20–30% lower than the values of exergo-technological criteria of efficiency for the corridor position of pipes at all Re^a values, which corresponds to a greater exergy efficiency of heat exchangers with checkerwise arrangement of pipes in a package of panels.

The scientific novelty of the results obtained is that based on the methods of exergy analysis in combination with other modern research methods, complex approaches to the study of the efficiency and optimization of heat-recovery systems of simple structure and their individual elements have been developed. These studies are the basis for the creation of complex methods for the analysis of efficiency and optimization.

The practical value of the conducted research lies in the fact that the obtained results of solving optimization tasks allow increasing the efficiency of heat-recovery systems of gas-fired power plants of various types and will be used in the design of these systems.

As a result of the work, we can draw the following important conclusions. Complex approaches to the analysis of the efficiency and optimization of heat-recovery systems of simple structure and their individual elements, based on the methods of exergy analysis, statistical planning method of experiment and modern methods of thermal calculation of heat transfer equipment of heat-recovery systems, have been developed and formed the basis of the relevant research methods. Examples of the use of the developed methods for optimizing the parameters of the water- and air-heater with the checkerwise and corridor arrangement of pipes in a package are shown. The optimal geometric parameters of the heat exchanger surface of the water heat-recovery exchanger and the optimal operating parameters of the air heat-recovery exchanger have been determined. It has been shown that the exergetic efficiency of water heat-recovery exchanger with pipes arranged checkerwise in a panel package is by 10% hig-

her than the exergetic efficiency of the heat exchanger with the corridor pipe arrangement. It has been found that the optimal ratio of Reynolds numbers Re^g/Re^a corresponding to the minimum of the obtained functional dependences increases as Re^a decreases. The exergy efficiency of air heat-recovery exchanger with pipes arranged checkerwise in a panel package is by 20–30% higher than the exergy efficiency of the heat exchanger with the corridor arrangement of pipes.

Notation keys: b is membrane thickness; c_p is specific heat, C is water equivalent; d_1, d_2 is inner and outer pipe diameters; E is exergy; F is surface area; G is heat-transfer agent mass flow; H is membrane efficiency coefficient; h_m is membrane height; h is enthalpy; k is heat transfer coefficient; k_T is turbulization coefficient; l is pipe length; m is mass; N is the number of pipes in the heat-recovery exchanger; Nu is the Nusselt number; n is number of elements in the technological system; Pr is the

Prandtl number; p is pressure; Q is thermal power; R is the gas constant; Re is the Reynolds number; s is entropy; T is temperature; W is moisture content; z is the number of pipes in the transverse row; α is heat irradiation coefficient; α_c, α_r are convective and reduced heat irradiation coefficient; λ is coefficient of thermal conductivity; μ is molecular mass; v_p, v_i are functions of heat irradiation coefficients on the surface of the pipe and the membrane, as well as the ratio of the temperature head in the root of the membrane and on the surface of the pipe to the average temperature head on the heat transfer surface; ξ is pollution factor; ρ is density; ψ is conversion factor from counter flow scheme to repeatedly cross flow pattern; ω is speed.

Superscripts: a, g, w — air, exhaust-gas, water; ext —external; ins —inside.

Subscripts: en —environment; f —full; in, out —inlet, outlet; l —losses; m —membrane; p —pipe; pp —partial pressure; tot —total.

REFERENCES

1. Calise, F., d'Accadia, M. D., Macaluso, A., Piacentino, A., & Vanoli, L. (2016). Exergetic and exergoeconomic analysis of a novel hybrid solar–geothermal polygeneration system producing energy and water. *Energy Conversion and Management*, 115, 200–220. <https://doi.org/10.1016/j.enconman.2016.02.029> (Last accessed: 02.04.2020).
2. Seyitoglu, S. S., Dincer, I., Kilicarslan, A. (2017). Energy and exergy analyses of hydrogen production by coal gasification. *International Journal of Hydrogen Energy*, 42(4), 2592–2600. <https://doi.org/10.1016/j.ijhydene.2016.08.228> (Last accessed: 02.04.2020).
3. Taner, T. (2018). Energy and exergy analyze of PEM fuel cell: a case study of modeling and simulations. *Energy*, 143, 284–294. <https://doi.org/10.1016/j.energy.2017.10.102> (Last accessed: 02.04.2020).
4. Fialko, N., Stepanova, A., Navrodska, R., Meranova, N., Sherenkovskii, J. (2018). Efficiency of the air heater in a heat recovery system at different thermophysical parameters and operational modes of the boiler. *East European Journal of Enterprise Technologies*, 6(8), 43–48. <https://doi.org/10.15587/1729-4061.2018.147526> (Last accessed: 02.04.2020).
5. Fialko, N., Stepanova, A., Navrodska, R., & Presich, G. (2019). Localization of exergy losses in the air heater of the heat-recovery system under different boiler operating modes. *International scientific journal of Internauka*, 12. <https://doi.org/10.25313/2520-2057-2019-12> (Last accessed: 02.04.2020).
6. Fialko, N., Stepanova, A., Navrodska, R., Sherenkovskii, J., Sarioglo, A. (2016). *Monograph: Heat-recovery of the exhaust gases of glass melting furnaces using membrane pipes*. Kyiv: Sofia-A. 214 p. [in Russian].

Received 27.08.2020

Revised 16.09.2020

Accepted 01.04.2021

Н.М. Фіалко (<https://orcid.org/0000-0003-0116-7673>),
А.І. Степанова (<https://orcid.org/0000-0002-9297-8473>),
Р.О. Навродська (<https://orcid.org/0000-0001-7476-2962>),
Г.О. Гнедаш (<https://orcid.org/0000-0003-0395-9615>),
С.І. Шевчук (<https://orcid.org/0000-0001-8046-0039>)

Інститут технічної теплофізики НАН України,
вул. Марії Капніст, 2а, Київ, 03057, Україна,
+380 44 453 2859, +380 44 456 9171, admin@ittf.kiev.ua

КОМПЛЕКСНІ МЕТОДИКИ АНАЛІЗУ ЕФЕКТИВНОСТІ ТА ОПТИМІЗАЦІЇ ТЕПЛОУТИЛІЗАЦІЙНИХ СИСТЕМ

Вступ. Вирішення загальної проблеми енергозбереження в Україні пов'язано з необхідністю підвищення ефективності енергетичних установок. На сьогодні можливими є дослідження окресленого питання для систем утилізації теплоти відхідних газів паливоспоживальних теплових установок різного призначення з позицій сучасних комплексних підходів.

Проблематика. Однією з причин, що гальмує широке використання теплоутилізаційних систем для зазначених енергетичних установок, є низька ефективність цих систем через недосконалість наявних методів їхнього аналізу та обладнання, що застосовується.

Мета. Створення комплексних методик аналізу ефективності та оптимізації теплоутилізаційних систем простої структури та їхніх окремих елементів.

Матеріали й методи. Використано комплексні підходи на основі методів ексергетичного аналізу, статистичних методів планування експерименту та сучасних методів теплового розрахунку теплообмінного обладнання систем теплоутилізації.

Результати. Розроблено методики аналізу ефективності та оптимізації для теплоутилізаційних систем газоспоживальних теплових установок із застосуванням двох способів отримання функціональних залежностей для оптимізації простих теплоутилізаційних систем або їхніх окремих елементів. Наведено приклади використання запропонованих методик для вдосконалення водо- та повітрогрійних теплоутилізаторів у системах утилізації теплоти відхідних газів скловарної печі.

Висновки. На основі методів ексергетичного аналізу, статистичних методів планування експерименту та сучасних методів теплового розрахунку теплообмінного обладнання систем теплоутилізації розроблено комплексні підходи щодо аналізу ефективності та оптимізації теплоутилізаційних систем простої структури та їхніх окремих елементів. Отримані результати вирішення оптимізаційних завдань дозволяють підвищувати ефективність теплоутилізаційних систем газоспоживальних енергетичних установок різного типу і будуть використані при проектуванні цих систем.

Ключові слова: газоспоживальні теплові установки, утилізація теплоти відхідних газів, водо- і повітрогрійні теплоутилізатори, критерії ефективності.