

Berezovsky, Yu.V.Kherson National Technical University,
24, Beryslavs'ke shose, Kherson-8, 73008, тел. +38 (0552) 32-69-81

APPLICATION OF NEW TECHNICAL DECISIONS IN THE INDUSTRIAL FLAX PRODUCTION



The use of flax and flax-containing products in the economy and increase in its output require modifying the qualitative and quantitative properties of the flax fiber. The research concerns the features of the effects of timber and other non-fibrous impurities of stem material on the fiber integrity during deformation of plant stems in the flax processing. The modifications in the process equipment for bast raw material processing have been showed to effect the results of stem material treatment, especially, the degree of purity of the obtained fibrous product.

Keywords: fibre, flax, raw material, quality, cleaning, processing, equipment, and production.

Flax belongs to the most ancient cultivated crops. The main countries whose climatic zones allow it to grow are as follows: Ukraine, Russia, Belarus, the Baltic States, Poland, China, India, France, and others. In the world there are more than two hundred species of flax, including 29 varieties cultivated in Ukraine. The main among them are common flax and flax oil [1–3]. Due to their unique properties the natural products from common flax and flax oil and their derived products are in demand both in domestic and foreign markets of Ukraine [4, 5].

The scope of flax application is wide and varied. Its exceptional properties make the linen cloth irreplaceable in creating the comfortable garments. A flax fiber is widely used in the textile industry and can be successfully used on its basis in obtaining cellulose ethers and other products. In addition, the flax oil fiber can be used in the production of nonwovens for various purposes and reinforcement of structural polymeric materials for various industries. The fibrous waste of common flax processing is used for this purpose.

Virtually, all the parts of the mature flax plants can be used as raw materials for the various industries. Due to the water absorption, breathability, ability to create antiseptic conditions the flax-containing materials are used in medicine. In the recent years, there has appeared a technology of producing the cotton batting with a high filtering ability which prevents infection and reproduction of microorganisms and does not cause inflammation and allergic reactions; technologies of manufacturing atraumatic bandage and surgical linen thread. Nowadays, technical linen is used in automobile, aviation, footwear and rubber industry. The flax processing products are good raw materials for the production of nonwoven materials. Such flax processing wastes as geotextiles are used for strengthening of embankments, slopes, banks of reservoirs, hydro-technical structures and in the construction of roads.

In comparison with other plants the flax contains the largest amount of cellulose. By its structure the flax is a complex polymer composition comparable with the structure of composite material. Elementary fibers with oriented structures are the reinforcing element and amorphous,

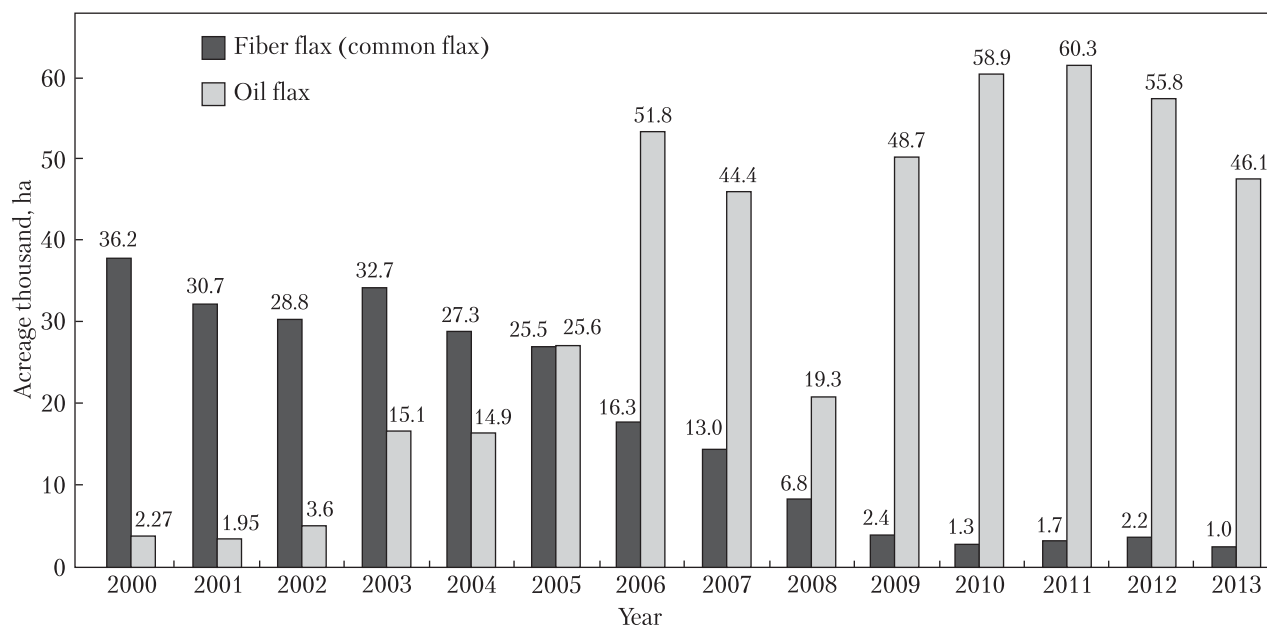

Fig. 1. Dynamics of flax acreage in Ukraine in 2000–2013

lignin-carbohydrate composition is a polymer matrix. The flax stem material which contains 50 percent cellulose is a good raw material for the production of paper and cardboard. The waste from processing the stalks for fiber (shive) is used in the production of building materials and furniture [6]. Materials from this plant make it possible to reduce the weight of parts up to 20 percent and improve their thermal and sound-insulation properties.

For many decades, Ukraine has traditionally been one of the world's largest producers and exporters of flax fiber and the flax processing products. In the early 90s of the last century, the average area of flax cultivation made up 162.7 thousand hectares, and technology of intensive common flax cultivation was used on more than 100 thousand hectares. Gross yield of fiber and seeds was respectively 106.5 and 46.5 thousand tons. The fiber yield was 9.5 quintals and 2.9 quintals of seeds per hectare [7].

Until the middle of the twentieth century, the crop area of linseed oil made up about 100 thousand hectares that indicates at a sufficient spread of the culture in Ukraine. The highest linseed oil

cultivation took place in the south-eastern regions of the country. In the recent years, one can observe a tendency to increase its acreage, but it should be noted that such a valuable culture as linseed oil has not been used in the industry. Mainly, this is due to a higher spread, growth of technological developments of common flax processing and socio-economic circumstances prevailing in the country and in the world.

According to the State Statistics Committee of Ukraine, beginning from 2006 up to 2013, the common flax cultivated area in our country decreased from 16.3 to 1 thousand hectares. As a result, the raw linseed for the production of textile products and cottonine almost disappeared. However, one could observe a significant increase in the cultivated area of linseed oil (Fig. 1) [8].

The domestic linen industry is developing at the expense of its own raw materials and produces almost 7.3 percent of the country's textile fabric. The country was engaged in a complete cycle of flax production and processing. Enterprises, the main producers of linen products, are concentrated in Rivne, Zhytomyr, Chernihiv and Lviv regions; factory of technical fabrics is locat-

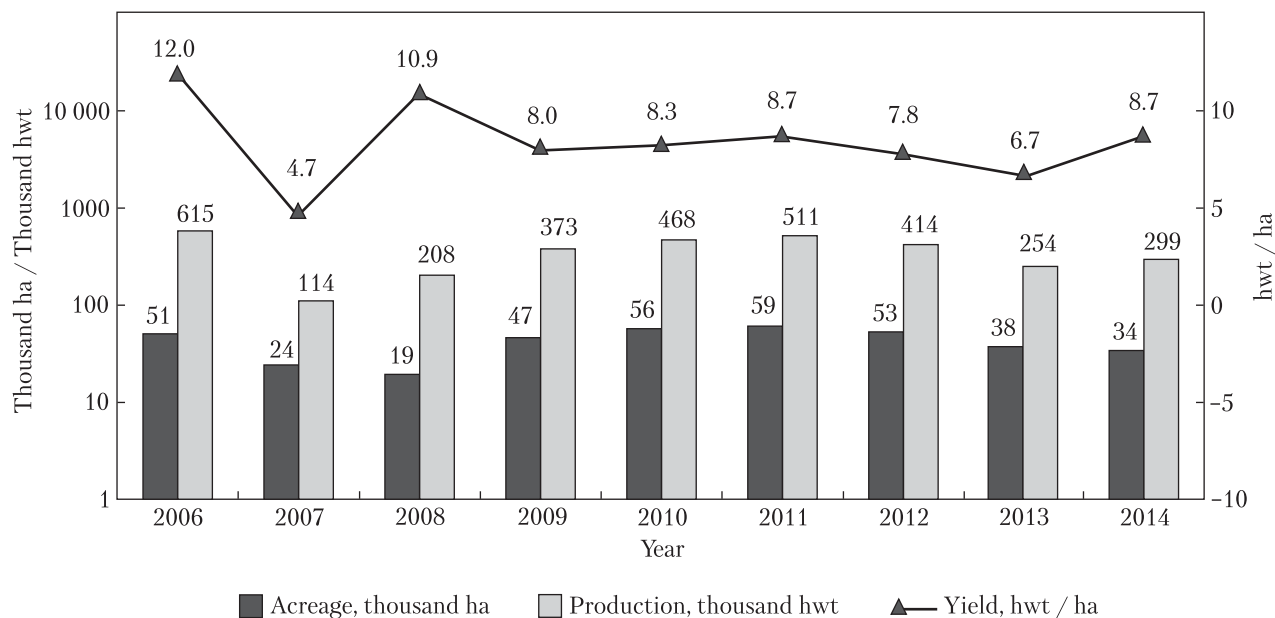

Fig. 2. Dynamics of linseed production in Ukraine

ed in Odessa, the twisted articles factory in Kirovohrad and the rope factory in Kharkov. Linen fabric is about 11.3 percent of the total fabric production in Ukraine. Production of this industry fully meets the needs of Ukraine, and some part is exported. In Ukraine, there are more than 30 flax mills and 2 linen factories. The primary processing of flax is carried out in a small flax mill tending to the raw materials. They are located in the north of the country where the major crops of common flax are concentrated (Zhytomyr, Rivne, Lviv and Chernihiv regions). The direct production of linen fabric is done in Rivne and Zhytomyr.

Up to 1991, the linen industry played a decisive role in the economy of Ukraine's Polissia farms. The flax share in the total crop sales revenues made up 30–70 percent and in some farms even more. Level of profitability of the industry ranged from 60 to 160 percent. Such figures were provided through relatively high yields of high-quality products and purchase prices for the linen products, appropriate incentives of producer and support by state of processing plants, etc.

In 1995, there was a collapse of flax-mill in-

dustry. Flax, which so far has been the most profitable crop of the Ukrainian Polissia and Carpathians, became unprofitable in the majority of agricultural plants. Also, the industry suffered great losses in 1995–2001, when the flax processing complex was in the difficult socio-economic situation. This greatly affected the social life of the population of these regions and brought tension in the society.

Slumping dynamics of flax fibers production were caused by changes in the structure of domestic business, low innovation activity of enterprises, lack of incentives, significant technical and technological backwardness of domestic textile industry from the level of leading foreign countries, increase in the energy and material consumption, labor intensity of production, lack of working capital and by poor organization of economic activity.

In 2003–2009, one could observe a relative stabilization of the Ukrainian flax processing complex. Flax cultivated area increased and achieved 25–30 thousand hectares. The annual production of flax fiber came to 15–18 thousand hectares. However, in the past few years the flax

cultivated area did not increase and remained in the range of 55–60 thousand hectares. Despite the relative stabilization, the linen complex has a great number of problems: a small area of common flax crop and almost complete absence of crown flax; small number of domestic seeds and high cost of imported ones, poor yield; low quality of raw materials, outdated equipment at the flax processing plants, low-effective technologies to obtain a small amount of scutching flax, an extremely low percentage of the available space (up to 20 percent); lack of national advanced processing technology; lack of innovation and a very small amount of investments both in the industrial and in the agrarian sector of linseed production; lack of standards for the linen products [7].

Yet, in the recent years Ukraine's interest in the production of linseed oil grew sufficiently, because there has been existed a great demand for the linseed oil export to the European countries, the USA and Canada which has made up nearly 40 thousand tons annually. However, the stem material of linseed oil is hardly used. In the most cases it is not in demand, therefore, directly in the field the stalks are plowed or burned which leads to the significant environmental problems. In 2014, 34.4 thousand hectares were involved in sawing of this culture. The main areas for the linseed oil sawing are Dnipropetrovsk, Zaporizhia, Mykolaiv and Kherson Oblasts. In the recent years, the climatic conditions have changed dramatically in direction of warming, so the linseed oil cultivation has become topical, especially in the southern and eastern regions of Ukraine [9], because the recent studies indicate that in the world market conditions today and in the nearest future the main advantage will be given to the linen fabrics and products. In the West European structure of manufacture of linen, clothes and underwear stock make up 60–75 percent, including knitwear (14–45 percent).

In the European market the need in the flax fiber is nearly 120 thousand tons per year and this need is growing. The American market demand is estimated in the same amounts. Today,

the need in linseed fiber has been met at 70–80 per cent. It is necessary more than 20 thousand tons of linseed fiber in order to meet the annual needs of domestic textile industry. Today, our needs have been met only by a third, therefore, the question arises as to the flax cultivation and providing the textile enterprises with the raw materials.

In the recent decades, manufacturers of fabrics in the pursuit of low cost and speed of manufacture, came to the industrial production of artificial and synthetic fabrics, paying no attention to the most valuable qualities of natural materials which protect the human health, and without thinking about great damage for the Earth, caused by the production of synthetic raw materials, processing and utilization of such products. However, with the increase in population and the need to meet its needs for the high-quality organic food, hygiene and eco-friendly products of light industry, more acutely the question arises as to the increase of flax fiber production, improvement of workflow processing, thus saving the valuable properties of flax, and use of innovative heritage in the industry.

Despite the demand in the flax-containing products in the world, in Ukraine little attention is paid to the development of this sphere of the national economy. Today, one can name a number of negative phenomena that hinder the development: outdated technologies of stalk material processing, morally and technically obsolete equipment, loss of professional staff, lack of working assets due to the constant rise in prices for the energy resources, lack of investments due to the country's demotivation in the development of the given branch of the industry and absence of efficient and effective legal, regulatory framework. Investors do not want to risk their funds, investing them in such production.

With the development of Ukraine's relations with the world partners (especially, with the countries-members of the European Union), strengthening of competition in the commodity market where exist real civilized laws, and manufacturers

operate and survive in the competition only due to constant updating of production, the domestic light industry cannot avoid the implementation of necessary innovation, know-how, technical upgrading of production processes, in particular in the linen processing industry which has outdated inefficient, energy-intensive machinery. Therefore, the search and development of advanced technical and technological developments that can contribute to improving the technology of industrial processing of linen products, development of production of goods with high value-added and obtain a positive socio-economic impact is an extremely important issue for our time, especially when it concerns the scope of cleaner and safer production of linen products.

ANALYSIS OF RESEARCH AND IDENTIFICATION OF OUTSTANDING PROBLEMS

Theory and practice implementation in the production of advanced technologies and equipment for the raw linseed processing [1–4; 10–17] provide the basis for the assertion that at present state of economic development of Ukraine the achievement of positive results from the processing of flax stalks (especially, little popular types) is possible through the use of innovative technologies in the enterprises on the basis of anatomical, physical and mechanical properties of flax stalks, new technical solutions and original methods of processing with the help of new devices, as well as new trends in the consumer market.

In addition, as a result of the research the use of traditional flax processing technology with division for long and short fibers for the linseed oil processing, as well as a low efficiency of the existing technological equipment has been recognized as inappropriate. Analysis of technology, disclosed in sources [15, 16] shows that for the same type of fibrous mass from the dew retted straw, the different bulky equipment should be generally used.

In the recent years, both in Ukraine and in the world one could observe the formation of scientific basis for the creation of new technolo-

gies for refining and processing of linen cloth, design of advanced modern equipment or its nodal components which as a result of their implementation can contribute to the improvement of their quantitative and qualitative indicators of the finished products. Unfortunately, today this matter has been disclosed poorly from the point of view of creating and using the node components of crumple-scutching unit that due to the technical solutions can improve the process of raw linseed cleaning.

The purpose of this work is to solve the problem of search and constructive transformation of equipment for the raw linseed processing which due to the innovative solutions makes it possible to improve the qualitative and quantitative indicators of the refined raw linseed. The article shows the modern ways of linen industry, especially the raw linseed processing and ways of growing the technical level of technological equipment.

RESEARCH AND JUSTIFICATION OF THE RESULTS

It is known from the history that any breakthrough in the economic and social development of the mankind always was closely connected with the use of high-tech developments which have significant advantages over the previous ones. In case of increased competition, manufacturers of goods and services are often forced to refer to the scientific ideas since the use of high-tech scientific developments, both in engineering and in technologies, helps to get a new generation of products which have some new peculiarities and properties, which, as a whole, play a decisive role in the competitive struggle for the consumers. In light industry, which constantly updates the assortment of goods, and consumers are strongly influenced by fashion, such tendencies in the production of linen products are very important.

Of special importance for the domestic textile industry is a perspective of using the short flax fiber and scutching refuse for the production of cotton-like fiber, cottonine, in order to get mixed

yarn fibers and fabric. The yarn production from cottonized flax fiber mixed with cotton makes it possible to reduce the need in cotton by 30-50 percent. On the basis of R&D, the engineering companies create the equipment for producing the cottonized flax fiber. It should be noted that the mixed fabrics and their products have high quality and the unique properties.

For the flax fiber processing it is necessary to prepare it accordingly, i.e. to approximate its properties to cotton and wool. There are three ways of preparing the flax fiber: chemical, physical and chemical, as well as mechanical. The mechanical way of preparing the flax fiber, which has a number of varieties, has gained the greatest distribution due to its technological simplicity and sustainability. A short-spun flax made by help of mechanical technology is received by two methods: breaking and cutting.

The method of breaking technology in the majority of cases provides the processing of non-oriented fibers in bulk. The method of cutting is used for the fiber in line. The mechanical method by way of cutting process was developed by *Laroche* (France), *Temafa* and *Truetzschler* (Germany), *Rieter* (Switzerland), *SPGUT&D*, *Legmashdetal*, and *Ivchesmash* (Russian Federation) [18]; [19].

Deep processing of short flax fiber makes it possible to provide the light industry with constantly updated raw linseed, expand the use of flax, create economically favorable terms in the agriculture for selective flax growing and its initial processing on the basis of intensive agricultural technologies and to preserve the extended recreation of flax as the most important technical culture, to get the guaranteed employment of highly qualified and working –age labor force in the village, reduction of dependence on the cotton and wool supplies from abroad, even in the presence of foreign currency allocations for these purposes.

In the recent decades, in the world markets the prices for cotton and its products have increased, that leads to a shortage in Ukraine of

raw linseed for the production of textile materials and it contributes to the reduction of foreign currency working assets of light industry enterprises. Thus, it should be noted that the available stocks of linseed oil stem material in Ukraine are almost never used, though its fiber is the closest to the cotton in the industrial production of various cellulose-containing materials [10, 21]. However, for the widespread use of linseed oil and other bast cultures in the textile industry it is necessary to further develop the appropriate technologies of processing which are still insufficiently developed and implemented. The lack of simple technologies and equipment, affordable by price for the agricultural producers and small business is a significant constraint for the implementation of processing the linseed oil stem mass for the fiber.

The producers are proposed to process the linseed oil stem mass by way of the so-called a single-type fibrous product. Testing of the linseed oil batches on the standard tow-preparing machine showed the need in the double passing of material on the unit in order to receive the shive-free fiber mass. However, the double pass technology causes a failure of technological process and disrupts the rhythm. Therefore, today, it is worth carrying out the works on creating the low-cost technologies for the linseed oil stem processing.

Study of technologies noted in sources [13, 15] show that for improving the mechanical processing of flax stalks and fiber it is necessary to provide the initial mixing of stems, their drying, the repeated shive delignation and especially effective mixing of fibers released from different parts of the stems. For receiving a quality semi-finished product from such raw material it is necessary to include in the technological process the additional operations of single-type fiber cleaning from shive, which, in its turn, can lead to rise in price of processing, and, as a result, to rise in the cost price of the finished products.

The fiber is the main finished product of technological operations of bast raw materials pro-

cessing which necessarily requires the use of special machines. It is connected with the specifics of mechanical processing of raw materials of plant origin – the retted straw, which has certain structural features.

The effect of external forces in the cross-clenching of the flax stem may be different in the perimeter of cutting. Basically, under the action of the working parts of crumple-scutching unit one can observe the force effect on a single stem or a group of retted stalks in the absence of restrictions on the sides and in the presence of such restrictions by the action of clenching forces in the mutually perpendicular and some other directions [22, 23].

Front clenching does not lead to negative consequences for the straw, but for the retted stalks it leads to the unwanted results, reduction of quantitative and qualitative indicators, i.e. output of long flax fiber and decline in its quantity.

Under conditions of the lateral restrictions the nature of stalk deformation in the cross clenching is not the same for various cultures and for their shape. The given process may be affected by such factors as pressure, surface area of the working part, thickness of stem tube wall, etc.

The process of dry stalks deformation also consists of several phases. First, there appear cracks, breaks and flexes on the stalks and then complete flattening of stalks with the formation of great number of cracks and breaks. In the process of dry stalks clenching, as a result of their fragility, unevenly and spasmodically there arise deformations and cracks. It should be noted that the flax due to the presence of bast fibers, which perform the function of reinforcement in the construction of plant during its growth, in dry condition it is often subject to flexes, breakage and only thereafter to cracking.

The flax stem resistance to folds is a normal reaction of plants on the external influence both of natural factors and on the actions of the working parts during the mechanical processing.

The main operations of technological processing of bast cultures are considered to be crum-

pling and scutching since such processes, first of all, affect the quality indicators of the resulting fibers, though herewith other related treatment processes, such as preparatory processes of the formation of stem roll, carding, alignment and stems parallelization in the roll, structuring and thinning of the retted ball also contribute to the final result of the processing. Thus, the authors of works [24, 25] show that due to the use of the advanced technology of preparing the retted straw roll to mechanical processes one can achieve a percent increase in the output of long scutching fiber, and at the expense of modernization of re-coiling machine design that leads to improving the process of unwinding the roll of the retted flax-fiber, reduce the defects and increase the output of long fiber.

Kneading process of fiber allows to destroy link with a woody portion and to dissolve the wood into pieces for easier removal of shive in the process of scutching. Short pieces of woody portion are separated much easier than long ones due to a smaller surface of adhesion. During passing of the retted straw through each pair of breaking rollers a number of grooves and force of their pressure increases and, as a result, degree of destruction of non-fibrous impurities goes up. The retted straw kneading has some drawbacks. One of them is the damage to the fiber itself in the kneading process. The initial stem collapsing allows you to divide the outer woody portion for several sections. The number of such sections depends on the clenching force of edging rolls and condition of the retted stalks. Herewith, the fiber part remains resistant to such influence and due to its flexibility a shift of fiber part with respect to the woody portion takes place. Then the stem under the influence of breaking rollers begins to wrinkle taking a form of rollers profile. The force of pressure on the stem in the first pair of breaking rollers is slight, therefore the woody portion of the stem begins to destroy, and the fibrous part remains uninjured. This is explained by the difference in the physical and mechanical properties. Further,

the breaking processes are repeated in a similar form, but according to selected technology of processing the pressure on the retted stalks ball is changed, as well as a quantity and a form of grooves. The edges of rollers grooves have a certain rounded radius in order to avoid the fibers cutting during the kneading process.

The raw linseed which goes to the breaking machine for processing is inhomogeneous by its physical properties. It consists of stalks of different thickness, degree of maturing and humidity. Some stalks have different critical length of broken sections, and also different angle of breakage. Herewith, such figures are not the same in each stalk. They are different for the root and top end.

The fiber sprits are very important indicators of quality in the technological processing of crumpling, scutching and shaking of stem material. All working parts of machines in the technological processes of crumpling and scutching are adjusted to the intensive processing of bast material in order to break as much as possible the links between the woody and fiber portions with the removal of non-fiber additives [22]. Herewith, in the production the necessary balance in the technological processing should be observed.

In the total number of technological processing of bast cultures stalks the process of kneading of the flax stalks occupies an exclusive place, since from its efficient passing depend the further technological operations, and thus, the quality and quantity of the finished fiber products. Herewith, having the advanced equipment for the appropriate stage of processing one can receive a higher-quality fiber and in a larger quantity.

All technological processes are aimed at the removal of the fiber mass from the woody portion and other non-fiber additives and at the maintenance of the fiber integrity. Separation of additives in the form of shive and other additives take place thanks to the mechanical influence on the flax stalk and difference in the physical and mechanical performance of composite stems. It should be noted that the formation of

shive the edges of which acquire a chaotic shape is particularly dangerous for the fiber. Most of the shive particles have sharp edges which as a result of contact with fibers lead to micro-cuts that contribute to their further break in the process of scutching.

According to the informational analysis, as well as the experimental and theoretical studies made on the basis of Kherson National Technical University, it was designed several types of rollers for kneading the stalks of bast cultures and crumpling units for cleaning the raw material in the crumple-scutching aggregate [26–29]. The rollers due to their constructive peculiarities may solve the problem of improving the conditions of intaking the stalks for kneading by a pair of rollers, increase in the efficiency of their kneading, ensuring the efficiency of cleaning the raw material and increase in the coefficient of friction of the rollers surface with the stalks which, in a whole, improve the efficiency of the entire aggregate.

In each of the proposed models the tasks were solved with a help of appropriate constructive changes which improved the effect of mechanical action of the machine parts on the bast raw material.

For the crumpling roller, which is a hollow cylinder, in the holes of which there are grooves of steep and shallow profiles along the entire length (Fig. 3), the task was solved in such a way that on the roller at the grooves tops there were micro-grooves of steep grooving, herewith above and under the pair of such rollers there were stiff brushes.

The use of micro-grooves at the groove tops along the entire length of the roller instead of polished surface of tops makes it possible to ensure the increase in the efficiency of intake of bast cultures stalks, increase the coefficient of adhesion of rollers surface with their stalks, improve the efficiency of their kneading and fiber separation from the woody portion at the expense of simultaneous passing of processes of cross compression, flexing and breaking of the

woody portion of stalks, sliding flexing and shift of shive with respect to the fiber, which improves the efficiency of cleaning. The use of stiff brushes located above and under a pair of rollers makes it possible to ensure cleaning of micro-grooves from their possible blockage by the wood particles and mud.

Thus, Fig. 3 schematically shows the interaction of the linked pair of rollers of breaking machine for the kneading of bast cultures stalks and the enlarged projection the micro-grooves of steep grooving for the constructive execution of grooves tops of breaking machine roller.

The breaking machine roller works in the following way. For kneading of the bast culture stalks from the roller 1 of the proposed construction a pair of rollers 1 is collected which is interconnected kinetically, and rotates from a drive. Herewith, the grooves 3 of one of the rollers of pair 1 are between the grooves 3, other by entry, that is, between the rollers centers the distance is less than diameter D of the roller 1. The bast culture stalks (for example, the retted straw) are formed in the ball, 2–4 stalks in thickness. Herewith, the stalks in the ball are located at the angle of 45 degrees in relation to them. After the stalks delivery to the rollers 1, that rotate, the stalks are captured by the grooves 3 of rollers 1 and drawn into zone 6 of interaction of linked pair of rollers 1 for kneading the bast culture stalks. Herewith, drawing of stalks is provided by virtue of frictional interaction conditions, namely, $\operatorname{tg} \beta < K$, where β is angle between the tangent point of stalks collision with the rollers surface and the direction of the stalks movement, and K is coefficient of roller surface rubbing against the stems.

As a result, taking into account the stems interaction the stalks ball is captured by the rollers 1 and efficiently kneaded thanks to the micro-grooves 4 on the top grooves 3 of the rollers 1 which improve the frictional interaction. The presence of micro-grooves 4 on the grooves tops 3 of rollers 1 makes it possible to ensure the required load on the raw material and the speed of

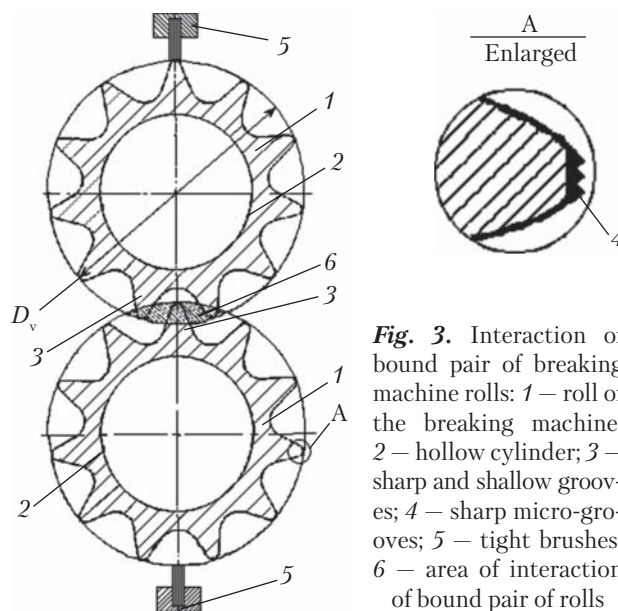

Fig. 3. Interaction of bound pair of breaking machine rolls: 1 – roll of the breaking machine; 2 – hollow cylinder; 3 – sharp and shallow grooves; 4 – sharp micro-grooves; 5 – tight brushes; 6 – area of interaction of bound pair of rolls

its movement, create conditions for the simultaneous cross compression, flexing, breaking of the stalks wood, formation of additional number of points of the stalks woody portion destruction which improves the processes of flexing, breaking and separation of the fiber from the wood, sliding flexing and shift of the shive in relation to the fiber. The micro-grooves 4 are made as micro-grooves of steep grooving on the tops of grooves 3 of rollers 1. The stiff brushes 5 located above and under the pair of rollers 1 purify micro-grooves 4 from their possible blockage by the woody particles and mud.

The use of the given roller design allows you to ensure improving the efficiency of intake of the bast culture stalks, increase the efficiency of their kneading and separation of fiber from the wood, which leads to the possibility of its use in the industry.

In the roller for kneading of the bast culture stalks (Fig. 4) the assigned task was solved in the following way: on the roller which is a shaft with fixed disks, mounted at an equal distance between them, on the edges of which there are the unilateral deflections with a constant pace round, and between the disks there are bushings; on the uni-

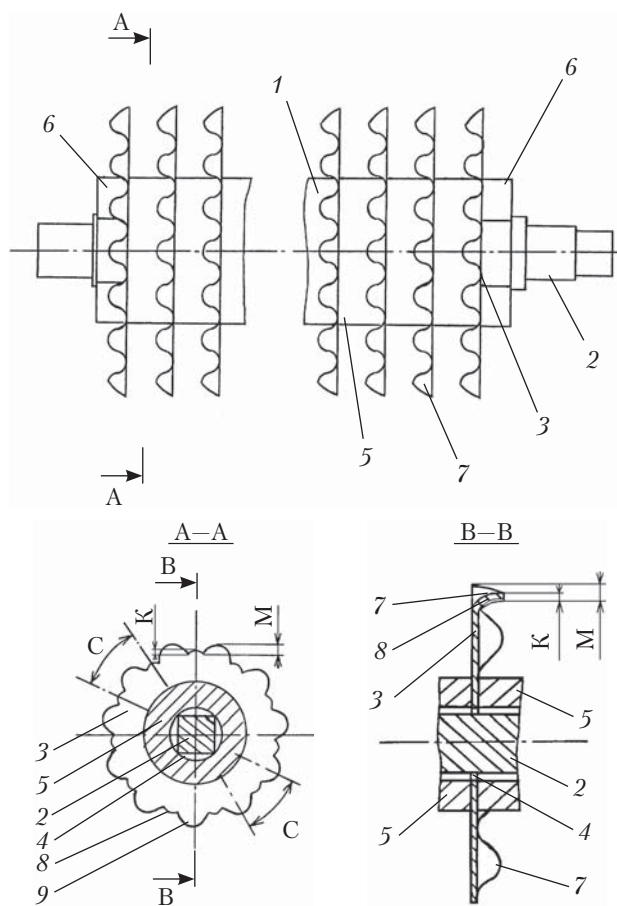

Fig. 4. Construction of a roller used to squeeze stems of bast plant cultures

lateral deflections across the entire height of deflections there are unilateral ruffs in the form of grooves of the assigned slopping or steep profile of grooving with constant pace round.

The use of the unilateral ruffs in the form of grooves of the assigned slopping or steep profile of grooving with the constant pace round at the unilateral deflections performed on the edges of the roller disks with the constant pace round makes it possible to improve the efficiency of intake of the bast culture stalks, increase the coefficient of adhesion of rollers surface with the stalks, improve the efficiency of their kneading and separation of fiber from the woody portion at the expense of simultaneous passing the processes of cross compression, flexing and breaking of the

woody portion of stalks, sliding flexing and shift of shive with respect to the fiber, which improves the efficiency of cleaning.

Fig. 4 shows a construction of a roller used to squeeze stems of bast plant cultures, shows cross-section of roller A—A and cross-section of disc B—B.

A roller to squeeze stems of bast plant cultures 1 is comprised of a barrel 2, produced from profile metal (tetrahedral shape, for instance), on both butt-ends of which there are seats to host bearings and driving gear wheels, discs 3 with apertures 4, a form similar to barrel cross-sections 2, plugs 5 of a certain width with discs placed between them 3, female screws 6 to be fastened by way of compression of discs 3, and plugs 5 at the barrel butt-end 2. On the edges of the discs 3 there are one-sided cavings 7, located circlewise with a regular interval C , on which one-sided ledges are located 8 in the form of roll flutes (hollow or steep specified profile) with a regular circlewise interval. Single-sided ledges 8 in the form of roll flutes (hollow or steep specified profile) with a regular circlewise interval protrude above the surface of cavings 7 at a K value. As a result of cavings, by the circles of the discs, 3 there appear ledges 9 at an M value.

The roller functions as follows. In order to squeeze the stems of bast plant cultures, the roller 1 of a proposed construction is used to assemble a couple of rollers 1 that are related cinematically and that perform the driven rotation. At the same time, discs 3 of one of the rollers 1 of the couple are located between the discs 3 of another one with an ingress—that is, between the centres of the rollers, 2 the distance is less than the diameter of the discs 3. Stems of bast plant cultures (for instance, flax stock) are formed into a layer, 2—4 stems thick. At the same time, stems in the layer are located either parallel to the axes of the barrels 2, or at an angle of 45° to them. After the stems are brought up to a pair of rollers 1, that rotate, the stems are captured by the ledges 9 of the M size discs 3, formed as a result of one-sided caving along the sides of the discs 3 and ledges 8

of the K size cavings 7 of the discs 3 formed as a result of their shaping in the form of roll flutes (hollow or steep specified profile) with a regular circlewise interval. At the same time, the condition of retraction of stems is retained, since under certain conditions alternating at a circlewise interval C along the circle of the discs, $\text{tg } \beta < K$, where β stands for an angle between the tangent to the point of stems contact with the surface of the discs and the direction of stems movement; K — stands for the coefficient of friction of the disc surface against the stems.

As a result of that, considering the presence of interrelation between the stems, one stem layer is captured with another with rollers 1 and is effectively passed through bending of the edges of the discs 3 a pair of rollers 1 and ledges 8 of a value K of cavings 7 of discs 3, formed as a result of their construction into a form of roll flutes (hollow or steep specified profile) with a regular circlewise interval. Presence of ledges 8 value K cavings 7 discs 3 allows to ensure the necessary loading onto raw materials and the speed of its movement; creates conditions for simultaneous cross-section compression, bending/breaking of the timber of the stems which facilitates processes of bending/breaking and separation of the fiber from the woody tissue, sliding type and shift of the flax shive off the fibre. Flax shive separated in the course of passing thus tumbles between the discs, reducing the possibility of fibre destruction and ensuring the increase of the passing of the stems.

Application of the aforementioned roller construction to pass the stems of bast plant cultures allows to increase the efficiency of suction of the stems of bast cultures and the efficiency of their passing and separation of the fibre from the woody tissue. At the same time, producing the rollers themselves may take place under the conditions of low labour intensity—that is, by way of punch-press production—which, in general, increases the efficiency of operation of the entire breaking and scutching machine and allows for its broad application on an industrial scale.

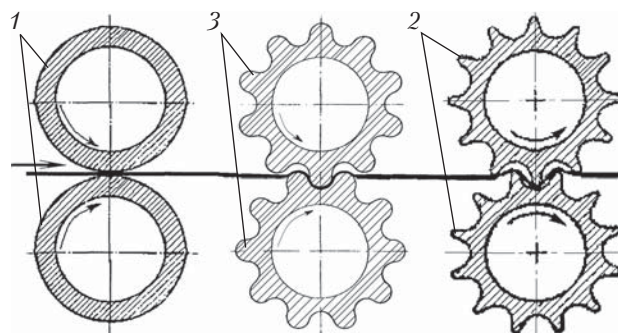

Fig. 5. The raw flax refining unit of the scutching and breaking machine

For the unit that is cleaning the raw material from the retted straw of the breaking and scutching machine (see Fig. 5) that contains breaking rollers (smooth, slanted, sharp-grained, and steeply-ribbed) with rectangular and corkscrew profiles assembled so as to be able to rotate on the framework of the breaking machine, the set problem was resolved in the following manner. The unit contained pairs of soft breaking rollers located before the pair of ribbed soft rollers for steep grooving in accordance with the specified profile, the unit contains at least one pair of ribbed breaking rollers for hollow grooving with a larger radius of rounding of the edge of roll flutes of steep grooving breaking rollers with a uniform clearance between the profiles of the edge of the roll flutes and the cavities of a pair of ribbed breaking rollers of the hollow grooving.

Introduction of a pair of ribbed hollow grooving breaking rollers of a larger rounding radius of the edge of the roll flutes into the unit that is cleaning the raw material in order to ensure uniform clearance between the profiles of the edge of the roll flutes and cavities of a pair of ribbed breaking rollers for hollow grooving allows to ensure a transfer of the necessary load onto material through larger area of contact as compared to smooth rollers. This creates conditions promoting the formation of a large number of centres of destruction of the woody substance of the stems, facilitates processes of bending/breaking and separation of the fibre from the woody sub-

stance due to the emergence of a sharp turn within a section shorter than a critical one in the subsequent pairs of steep grooving rollers of a specified profile, thus improving the efficiency of cleaning.

Fig. 5 shows raw material cleaning unit comprised of a pair of smooth breaking rollers 1, a pair of ribbed steep grooving breaking rollers 2, characterised by small rounding radius of the edge of the roll flutes and by relatively high roll flutes as compared to their interval and a pair of ribbed hollow grooving breaking rollers that are located between them and 3 have a larger rounding radius of the edge of the roll flutes as compared to the radius of rounding of the edge of the roll flutes of the ribbed steep grooving breaking rollers 2 whereby uniform clearance is ensured between the profiles of the edge of the roll flutes and cavities of a pair of ribbed hollow grooving breaking rollers 3.

The device functions as follows. A layer of retted straw stems prepared in a layer forming machine is fed into the breaking section of the breaking and scutching machine where it is flattened in soft smooth rollers 1 and fed into a pair of ribbed hollow grooving breaking rollers 3. Roll flutes of the upper breaking roller for hollow grooving 3 press the stems of the retted straw between the grooves of the lower breaking roller of hollow grooving 3, thereby exerting cumulative load in a closed space. At the same time, the bast fibres—owing to their natural flexibility—easily bend over the contours of the roll flutes of the breaking rollers for hollow grooving 3 and remain integral alongside the stems. The woody part of the stems is rigid and brittle; this leads to emergence of a large number of centres of destruction of the woody substance of the stems and facilitates the processes of bending and breaking and separation of the fibre from the wood due to the emergence of a fracture within a section shorter than the critical section in the subsequent pairs of ribbed breaking rollers for steep grooving of the specified profile 2. Depth of penetration of the roll

flutes of breaking rollers for hollow grooving is 3 adjusted so as to create the necessary loading onto the raw material without any change in the speed of its progression. After ribbed breaking rollers, 3 a layer of raw material proceeds forwards to the subsequent pair of breaking rollers for steep grooving 2 at a constant speed.

Shape of roll flutes in the pair of breaking rollers for steep grooving 2 is characterised by a small radius of rounding of the edge of the roll flutes and a relatively large height of roll flutes as compared to their interval. Such a pair of breaking rollers for steep grooving 2 performs technological operations of bending/breaking, sliding bend, and separation of the fibre from the woody substance, whereby the already broken raw material with a weakened cohesion between the flax shive and the fibre.

Depending upon the type and also upon physical and mechanical quality indicators of the raw material, the breaking and scutching machine may have one or several pairs of rollers installed onto it 1, 3 and 2 in order to perform effective cleaning of raw material from the retted straw. Therefore, the specified unit for cleaning raw material from retted straw in the breaking and scutching machine contributes to increase of the efficiency of raw material cleaning and can thus be applied in the industry.

For the unit that is cleaning the raw material from the retted straw of the breaking and scutching machine (see Fig. 6), that has breaking ribbed rollers of the specified profile that are assembled with a possibility of rotation on the framework of the breaking machine, the specified problem was resolved in the following manner. The unit contains at least two pairs of ribbed breaking rollers of the specified profile, one pair of breaking rollers for steep grooving with a small radius of profile contour and a relatively small height of roll flutes as compared to their interval, and a second pair of breaking rollers for steep grooving with a small radius of rounding of the edge of the roll flutes and a relatively large height of the roll flutes as compared to their interval that are in-

stalled in accordance with a calculated depth of roll flutes immersion between the rollers and possibility to rotate at a constant specified speed. At the same time, between the breaking pairs of ribbed rollers, there is a breaking pair of rollers for steep grooving that have a pectinated contour of the roll flutes profile and are relatively short as compared to their interval.

Introduction of a pair of steep grooving roll flutes into the unit for clearance of raw material that have a pectinated contour of the roll flutes profile and a relatively small height of the roll flutes as compared to their interval and are installed with a specified clearance allows to ensure the necessary load onto the raw material and the speed of its movement, creating conditions for simultaneous transversal compression, bending/breaking of woody material of the stems, a sliding bending, and shifting of the flax shive with regard to the fibre, which increases the efficiency of clearance.

Fig. 6 shows the clearance unit of the raw material from the retted straw of the breaking and scutching machine that is comprised of a pair of breaking rollers for steep grooving 1, with a small radius of the profile contour and a relatively small height of the roll flutes as compared to their interval; a pair of breaking rollers for steep grooving 2 characterised by small radius of rounding of the roll flute edge and relatively large height of roll flutes as compared to their interval, and a pair of breaking rollers for steep grooving 3, that have pectinated contour of the roll flute profile and relatively small height of the roll flutes as compared to their interval, installed in the framework of the breaking machine (not shown on Fig. 6) with a possibility of rotation.

The device functions as follows. A layer of retted straw stems prepared in a layer forming machine is fed into the breaking section of the breaking and scutching machine where it is flattened in soft smooth rollers and fed into a pair of ribbed hollow grooving breaking rollers 1. The form of the roll flutes in this pair of breaking rollers for steep grooving 1 has a small ra-

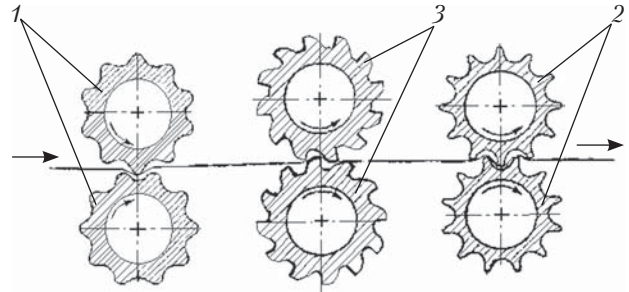

Fig. 6. The raw flax refining unit

dius of the profile contour and relatively small height of the roll flutes as compared to their interval. The roll flutes of the upper roller 1 press the stems of the retted straw between the roll flutes of the lower roller 1. At the same time, the bast fibres—owing to their natural flexibility—easily bend over the contours of the roll flutes of the breaking rollers 1 and remain integral alongside the stems.

The woody substance of the stems is rigid and brittle, thus the roll flutes break them and separate them into small sections. A careful process of *bending/breaking* of the woody substance of the stems of the retted straw is underway. The wooden remnants remain connected to the fibre. The ribbed breaking rollers 1 squeeze the layer of raw material and feed it into the next pair of breaking ribbed rollers 3 at a constant speed. The woody substance shifting with regard to the fibre is negligible.

A pair of breaking ribbed rollers 3 is comprised of the steep grooving rollers with a pectinated contour of the roll flutes profile and a relatively small height of the roll flutes as compared to their interval. This allows to ensure the necessary load onto the raw material and the speed of its relocation, thus creating conditions for simultaneous transversal compression, bending/breaking of the stem woody substance, sliding bend and shifting of the flax shive with regard to the fibre. Depth of penetration of the roll flutes of breaking rollers 3 is adjusted so as not to break the raw material and so that the necessary load be exerted onto it without a change in the speed

of its movement. Thanks to the special pectinated form of the contour of the roll flutes, the rollers 3 cause partial crushing of the woody substance, a longitudinal shift of a part of the stems with regard to the fibres, and at the same time do not break and do not damage them. Such processes lead to better separation of the woody particles (the flax shive) from the fibre that are being removed in the subsequent operations. After ribbed breaking rollers 3, a layer of raw material proceeds to the subsequent pair of breaking rollers 2 at a constant speed.

Shape of roll flutes in the pair 2 of breaking rollers for steep grooving is characterised by a small radius of rounding of the edge of the roll flutes and a relatively large height of roll flutes as compared to their interval. Such a pair of breaking rollers for steep rolling 2 performs the same technological operations as the pair of breaking rollers for steep rolling 1 – the only difference being that the raw material processing takes place more vigorously and the already broken raw material is subjected to processing, with weakened connection between the flax shive and the fibre and partially cleaned from flax shive.

Depending upon the type and also upon physical and mechanical quality indicators of the raw material, the breaking and scutching machine may have one or several such units installed in order to perform effective cleaning of raw material from the retted straw. Owing to the constructive specifics, the subject unit of the breaking and scutching machine contributes to the efficiency of raw material cleaning, thus allowing for the possibility of its application in the industry.

The aforementioned technical solutions addressing the stages after the breaking process allow improve the efficiency of removal of the flax sheave and the non-fibre admixtures, particularly in the process of scutching. Such conclusions have been corroborated by the results of the approbation within the facilities of Staryi Sambir Flax Processing Facility in Lviv Region. As a result, one might well assert that a more efficient

processing of the flax shive on the stage of scutching ensures a more efficient clearance of the fibre from the flax shive and non-fibre admixtures within the subsequent technological stages, thus at the end of the technological process of production, we obtain a more efficient fibre and in fact more of it.

Thus, thanks to the improvement of constructive particularities of parts of devices, one may ensure the expansion of possibilities for processing of all kinds of domestic bast fibre raw materials—that is, increase the universal scope of usage and efficiency of its processing as a whole. The fibre obtained through usage of constructive changes allows to expand the range of goods it is based upon and to use it in various realms of possible application.

Since in the most recent times, demand for environmentally clean products has increased and so has the number of users of «bio/green» goods, one may recommend the proposed design solutions to be implemented in the course of re-equipment of domestic light industry facilities and to develop the corresponding directions of innovative product development. The obtained flax fibre may be used to create a new product line or expand an existing one that is based on flax and flax containing materials, which allows to increase the scope of production and sales of flax-based products, although the technology of production is yet to be further enhanced and the items of various application are yet to be further assessed. Therefore, as of the present time, one needs to view this direction of industry development as a particularly promising one.

As of the present day, the task is to get ourselves engaged in the development of innovative products from environmentally safe groups of textiles and items produced in various manners and for different purposes, to compose requirements pertaining to the domestic segment of eco-market and to look for ways in which it can be further enhanced. Possibilities opened through application of the aforementioned technical developments well fit into such a conception. At

the same time, one ought to admit that, under the conditions of limited resources of hydrocarbons and increase in their price, Ukraine will be able to use the inexhaustible flax resource to produce textile goods that are ecologically safe for human health and the realm of its residence, since no toxic substances at all are emitted into the atmosphere in the course of their maintenance and disposal. Therefore, the suggested modernisation of the flax industry may contribute to further development of light industry as a whole, to reinforce domestic eco-market, to develop competitive flax-containing products with good prospects.

CONCLUSIONS

Considering the development of global and domestic industrial equipment to process bast plant cultures, one can assert that so far, there exists no sufficient universal-use technological equipment in Ukraine to undertake technical processing of a bast flax stock. This is why, at the present time, improvement of existing structures and design of more up-to-date equipment to process bast which would provide a possibility to enhance qualitative and quantitative characteristics of the output products will definitely become the target of crucially necessary researches. In order to do so, one needs to create conditions to get enterprises interested in mastering innovations and the results of scientific developments that are being undertaken to the benefit of development of the flax industry in Ukraine.

The suggested constructions of several types of rollers to pass stems of bast plant cultures and breaking clearance units for the raw material of breaking and scutching machine enable to resolve the matter of improving industrial processing and, in case they are applied in industrial conditions, they can not only positively impact the obtaining of high quality fibre but also positively influence domestic flax facilities in terms of its social and economic effect.

In further researches, it is necessary to conduct a detailed research into the change of quantita-

tive and qualitative indicators of fibre in course of technological process of processing of the stem material, to study the influence the changes in construction have upon them, and to reproduce the corresponding model to forecast the parameters of end products, thus enabling industrial application of the suggested constructions.

REFERENCES

1. Horach O.O. *Rozrobka tekhnolohii oderzhannia tresty iz solomy l'onu oliynoho z vykorystanniam shtuchnoho zvo-lozhennia* (Technology development of trust reception from straw of oil flax with the use of artificial irrigation). Kherson: KNTU, 2009 [in Ukrainian].
2. Zhyvetyh V.V., Gynzburg L.N. *Maslychnij len y ego kompleksnoe razvytye*. (Oilseed flax and its complex development). Moscow: TSNIILKA, 2000 [in Russian].
3. Chekhov A.V., Lapa O.M., Mishchenko L.Iu., Poliakova I.O. *Lon oliynyi: biolohiia, sorty, tekhnolohiia vyroshchuvannia* (Oil Flax: biology, varieties, growing technology). Kyiv: Ukrainska akademiia ahrarykh nauk. Instytut oliinykh kultur (Institute of Oilseed Crops of the Ukrainian Academy of Agricultural Sciences), 2007 [in Ukrainian].
4. Roi O.O., Tikhosova H.A. Perspektyvy kompleksnoho vykorystannia oliinoho lonu. *Lehka promyslovist* (Fashion & Textiles Industry). 2008, 2: 47 [in Ukrainian].
5. Maslianyi O. A lon tsvite syno, syno i na Pivdni Ukrainy. *Propozytsiia* (Proposition). 2003, 2: 40–41 [in Ukrainian].
6. Korotych P. Lon – nova perspektyva v rodyni oliinykh. *Propozytsiia* (Proposition). 2006, 2: 36 [in Ukrainian].
7. Levkovska T.V. Analiz syrovynnoi bazy tekstylnoi promyslovosti Ukrainy na suchasnomu etapi rozvytku ekonomiky. *Biznes-navihator* (Business Navigator). 2013, 1(30): 91–99 [in Ukrainian].
8. Boiko H.A. *Tovarovnavcha otsinka zmishanoi priazhi z voloknamy lonu oliinoho dlia trykotazhnykh vyrobiv* (Commodity grade mixed yarn fibers from flax oil for knitwear). Lutsk: LNTU, 2014 [in Ukrainian].
9. Maslak O. Pryvablyvist oliinoho lonu. *Ahrobiznes sohodni* (Agribusiness today). 2015, 4(299) [in Ukrainian].
10. Evdokymova Zh.V., Votchynykova S.N. Volshebnyk synyj len. *Perspektyva* (Perspective). 07.12.2001 [in Russian].
11. Makarenko P.M. *Rynkova transformatsiia ahrarynoho sektora: teoriia i praktyka* (The market transformation of the agricultural sector: theory and practice). Zaporozhye: ZNU, 2006 [in Ukrainian].
12. Povazhnyj A.S., Batchenko L.O., Djatlova Ju.V. Gosudarstvennaja podderzhka razvitija agrarnogo sektora

- jekonomiki: opyt i sovremennye tendencii (State-owned agricultural sector development support Economy: Experience and its contemporary trends). *Collection of scientific works of Donetsk State University of Management and enterprises*. 2004, V (38): 40–46 [in Russian].
13. Fedosova N.M. *Issledovanie svoystv l'na-mezheumka i obosnovanie metoda prognozirovaniya ego tekhnologicheskoy cennosti* (Studying the properties of flax-intermediate and justification of the method of forecasting its technological value). Kostroma: KGTU, 2002 [in Russian].
 14. Berezovskiy Iu.V. Otsinka peredumov rozvytku rynku tovariv z lonu v Ukraini. *Tovaroznavchyi visnyk* (Commodity Bulletin). 2014. 7: 19–27 [in Ukrainian].
 15. Pashyn E.L., Fedosova N.M. *Tekhnologicheskoe kachestvo y pererabotka l'na-mezheumka* (Technological quality and processing of flax-intermediate). Kostroma: VNIILK, 2003 [in Russian].
 16. Fedosova N.M., Peshkova A.S. Anatomicheskoe stroenye maslychnogo l'na. *Dostyazheniya nauky y tehnyky APK* (Achievements of science and technics APC) 2005, 10: 17–18 [in Russian].
 17. Smyrnova V.A., Fedosova N.M., Rysakov D.S. Yssledovanye dekortykatsionnoy sposobnosti solomi maslychnogo l'na. *Nauchnye trudy molodykh uchennykh KGTU* (Scientific works young scientists of KGTU) 2007, 2 (1): 54–58 [in Russian].
 18. Obzor sostojaniya tekstyl'noj otrasly. L'njanaja podotrasl'. Kotonyzrovannyj len. *Perspektyva* (Perspective). 2001–2002 [in Russian].
 19. Stokozenko V.G., Gubyna S.M. Kotonyzatsiya po-nauchnomu, yly kak səkonomyt' l'njanoe syr'e y rasshyryt' assortyment tkanej. *Perspektyva* (Perspective). 28.12.00 [in Russian].
 20. Smyrnov A.A. *Modelyrovanye processa droblenija kompleksov tehnycheskogo l'njanogo volokna* (Simulation of the crushing process of complexes technical flax fiber). Kostroma: KGTU, 2008 [in Russian].
 21. Holovenko T.M. *Rozroblennia tekhnolohii pererobky stebel'trestylonu oliinoho zmetoiu oderzhannianetkanykh materialiv* (Processing technology development trusts stalks of flax oil to produce nonwovens). Kherson: KNTU, 2013 [in Ukrainian].
 22. Hiliazetdinov R.N. *Rozvytok naukovykh osnov stvorennia innovatsiinykh tekhnolohii pervynnoi pererobky lub'ianykh kultur* (Development of scientific bases of creating innovative technology of primary processing of bast crops). Kherson: KNTU, 2009 [in Ukrainian].
 23. Valko P.M. *Udoskonalennia tekhnolohii oderzhannia tipanoho llianoho volokna z vykorystanniam ochyshchuvalnykh valkiv* (Improving the technology of flax fiber tipanoho using cleaning rolls). Kherson: KNTU, 2011 [in Ukrainian].
 24. Petrachenko D.O. *Udoskonalennia protsesiv formuvannia sharu lonotresty do mekhanichnoi pererobky* (Improving the process of forming a layer flax raw material to mechanical processing). PhD (Tec.) Kherson, 2014 [in Ukrainian].
 25. Muravynets Iu.V. *Udoskonalennia tekhnolohii pererobky llianoi tresty za rakhunok modernizatsii m'ialno-tipalnykh ahrehativ* (Improving processing technologies flax trusts by modernization scutching aggregates). PhD (Tec.) Kherson, 2014 [in Ukrainian].
 26. *Patent of Ukraine N 85880*. Berezovsky Yu.V. Roll of crumple machine [in Ukrainian].
 27. *Patent of Ukraine N 88838*. Berezovsky Yu.V. Crumple roll for stems by bast crops [in Ukrainian].
 28. *Patent of Ukraine N 82940*. Berezovsky Yu.V. Cleaning unit of flax raw material of crumple aggregate [in Ukrainian].
 29. *Patent of Ukraine N 70313*. Berezovsky Yu. V. Cleaning unit of flax raw material of crumple aggregate [in Ukrainian].

Ю.В. Березовський

Херсонський національний технічний університет,
Бериславське шосе, 24, Херсон-8, 73008,
тел. +38 (0552) 32-69-81

ВИКОРИСТАННЯ НОВИХ ТЕХНІЧНИХ
РІШЕНЬ У ПРОМИСЛОВОМУ
ВИРОБНИЦТВІ ЛЬЯНОЇ ПРОДУКЦІЇ

Застосування льяної та льономісткої продукції в народному господарстві і промисловості та збільшення обсягів її виробництва вимагають зміни якісних і кількісних властивостей льяного волокна. У статті встановлено характер дії деревини та інших неволокнистих домішок стеблового матеріалу на цілісність волокна в процесі деформації стебел рослин під час переробки льону. Показано, що конструктивні зміни органів технологічного обладнання переробки луб'яної сировини вплинуло на результати обробки стеблового матеріалу, особливо на ступінь чистоти отриманого волокнистого продукту.

Ключові слова: волокно, льон, сировина, якість, очищення, переробка, обладнання, виробництво.

Ю.В. Березовский

Херсонский национальный технический университет,
Бериславское шоссе, 24, г. Херсон-8, 73008,
тел. +38 (0552) 32-69-81

ИСПОЛЬЗОВАНИЕ НОВЫХ ТЕХНИЧЕСКИХ
РЕШЕНИЙ В ПРОМЫШЛЕННОМ
ПРОИЗВОДСТВЕ ЛЬНЯНОЙ ПРОДУКЦИИ

Применение льняной и содержащей лен продукции в народном хозяйстве и промышленности и увеличение объемов ее производства требуют изменения качественных и количественных свойств льняного волокна. В статье установлен характер действия древесины и других неволокнистых примесей стеблевого материала на целостность волокна в процессе деформации стеблей растений при переработке льна. Показано, что конструктивные изменения органов технологического оборудования переработки лубяного сырья повлияло на результаты обработки стеблевого материала, особенно на степень чистоты полученного волокнистого продукта.

Ключевые слова: волокно, лен, сырье, качество, очищение, переработка, оборудование, производство.

Received 17.02.16